

TUB

In-line extractor fans with a detachable body and small size for high temperatures (250 °C), designed for operation inside chimney ducts.



- Fan:**
- Sheet steel casing.
 - Impeller with blades made of galvanised sheet steel.
 - Closure that allows the body to be removed easily and quickly.
 - External terminal box.

- Motor:**
- Motor with long-life ball bearings and IPX4 protection.
 - Single-phase 220/-240 V-50 Hz.
 - Operating temperature: -10 °C +250 °C.

- Finish:**
- Anti-corrosive finish on heat-resistant paint.

Order code

TUB — 200

TUB: In-line extractor fans with a detachable body and small size for high temperatures (250 °C)

Nozzle diameter in mm

Accessories

See accessories section.



STUB

Technical characteristics

	Speed (r/min)	Max. admissible current 220-240 V	Max. electric power (kW)	Maximum flow rate (m ³ /h)	Irradiated sound level (*) (dBA)	Approx. weight (kg)
TUB-200	2780	0.30	0.068	250	39	7
TUB-225	2765	0.32	0.075	330	41	8
TUB-250	2760	0.35	0.080	400	43	9

(*) Irradiated sound pressure levels obtained at a distance of 3 metres in a free field, with rigid inlet/exhaust tubes.

Dimensions mm

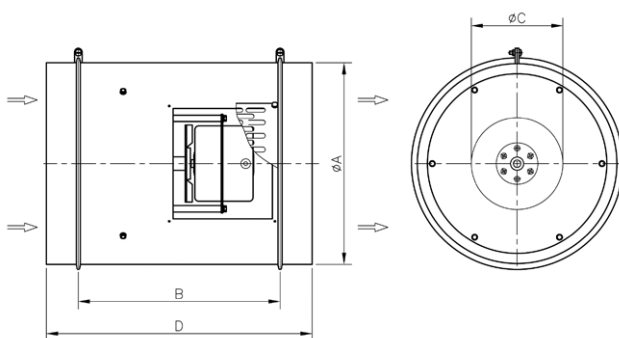

	øA	B	øC	D
TUB-200	200	255	116.5	355
TUB-225	225	255	116.5	355
TUB-250	250	255	116.5	355

Characteristic curves

Q= Flow rate in m³/h, m³/s and cfm.
Pe= Static pressure in mm H₂O, Pa and inwg

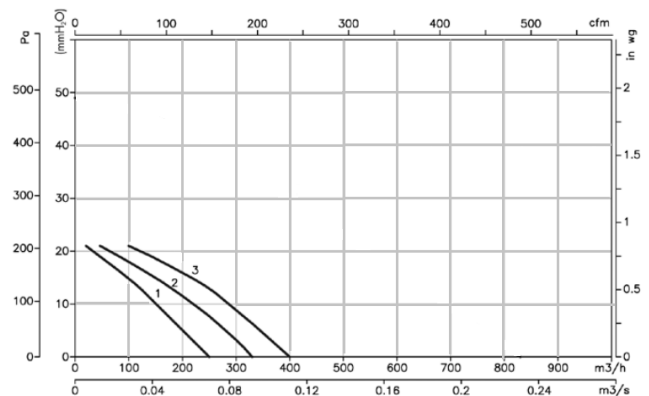

1: TUB-200 3: TUB-250

2: TUB-225