

HCDF HDF

HCDF: Axial fans with square frame, with ATEX Ex d certification
HDF: Axial fans with circular frame, with ATEX Ex d certification

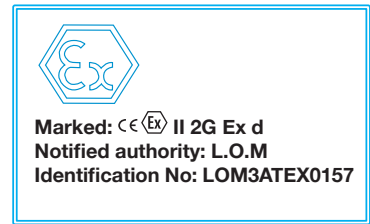

HCDF



HDF

Wall-mounted axial fans (HCDF) or circular fans (HDF) with ATEX certification and CEE ExII2G Ex d flame-resistant motor to work in explosive atmospheres.

Fan:

- Impeller made from cast aluminium
- Airflow direction from motor to impeller
- Flame-resistant stuffing-box included
- HCDF: Support frame in sheet steel with aluminium strip in the impeller area in accordance with Standard EN-14986:2007
- HCDF: Protection guard to prevent contacts according to standard UNE-EN ISO 12499:2010
- HDF: Support ring in sheet steel with aluminium strip in the impeller area in accordance with Standard EN-14986:2007

Motor:

- Class F insulation, IP55 with ATEX certification, Ex"d" IIBT4 flame-resistant
- Three phase, 50Hz, 230/400V motors up to and including 4kW. 400/690V over 4kW
- HDF: Fan working temperature: -20°C + 40°C
- HCDF: Fan working temperature: -20°C +50 °C

Finish:

- Rust retardant finish with ATEX paint, containing no ferrous components, in polyester resin polymerised at 190°C, after phosphate free pre-treatment

On request:

- Special windings for different electrical supplies and frequencies
- ATEX construction for different categories
- Fans with two-speed motor.



Aluminium strip to prevent sparks as per the EN-14986:2007 standard

Order code



HCDF: Axial fans with square frame, with ATEX certification
 HDF: Axial fans with circular frame, with ATEX certification

Marked: CE Ex II 2G c

Impeller diameter (cm)

Number of motor pole
 4=1400 r/min. 50 Hz
 6=900 r/min. 50 Hz

T=Three-phase
 M=Single-phase

Technical characteristics

Model	Speed (r/min)	Maximum current admissible (A)		Installed power (kW)	Maximum airflow (m³/h)	Sound pressure level dB(A)	Approx. weight (Kg)
		230V	400V				
HCDF-25-4T	1360	0.78	0.45	0.09	890	51	6.5
HCDF-25-4M	1235	1.00		0.06	890	51	6.5
HCDF-31-4T	1360	0.78	0.45	0.09	1700	54	7.5
HCDF-31-4M	1235	1.00		0.06	1700	54	7.5
HCDF-35-4T	1360	0.78	0.45	0.09	2950	58	8.5
HCDF-35-4M	1235	1.00		0.06	2950	58	8.5
HCDF-40-4T	1370	2.08	1.20	0.25	4400	63	12.5
HCDF-40-4M	1385	2.04		0.25	4400	63	15.0
HCDF-45-4T	1370	2.08	1.20	0.25	6450	66	14.5
HCDF-45-4M	1385	2.04		0.25	6450	66	17.0
HCDF-45-6T	900	1.39	0.80	0.12	5200	57	14.5
HCDF-50-4T	1370	2.60	1.50	0.37	8600	69	16.5
HCDF-56-4T	1410	2.94	1.70	0.55	10500	72	36.5
HCDF-56-6T	910	2.42	1.40	0.25	8400	63	30.5
HDF-63-4T	1410	5.20	3.00	1.10	15100	76	49.0
HDF-63-6T	935	2.77	1.60	0.37	12400	64	36.5
HDF-71-4T	1410	5.20	3.00	1.10	20000	79	52.0
HDF-71-6T	930	3.46	2.00	0.55	13800	67	43.0
HDF-80-4T	1440	12.30	7.10	3.00	34100	83	76.0
HDF-80-6T	910	5.89	3.40	1.10	20200	72	65.5
HDF-90-4T	1450	15.76	9.10	4.00	48200	89	87.0
HDF-90-6T	940	7.62	4.40	1.50	30000	77	83.0

Acoustic features

The specified values are determined according to free field measurements of pressure and sound levels in dB(A) at an equivalent distance of twice the fan's span plus the impeller's diameter, with a minimum of 1.5 m.

Sound power Lw(A) spectrum in dB(A) via frequency band in Hz.

Model	63	125	250	500	1000	2000	4000	8000	Model	63	125	250	500	1000	2000	4000	8000
25	22	37	56	55	56	55	50	41	63-4	52	66	85	85	86	84	80	71
31	25	40	59	58	59	58	53	44	63-6	40	54	73	73	74	72	68	59
35	29	44	63	62	63	62	57	48	71-4	56	76	84	89	91	88	81	70
40	34	49	68	67	68	67	62	53	71-6	44	64	72	77	79	76	69	58
45-4	37	52	71	70	71	70	65	56	80-4	60	80	88	93	95	92	85	74
45-6	28	43	62	61	62	61	56	47	80-6	49	69	77	82	84	81	74	63
50-4	43	57	76	76	77	75	71	62	90-4	67	88	95	100	103	99	92	81
56-4	46	60	79	79	80	78	74	65	90-6	55	76	83	88	91	87	80	69
56-6	37	51	70	70	71	69	65	56									

Dimensions in mm

HCDF 25...50

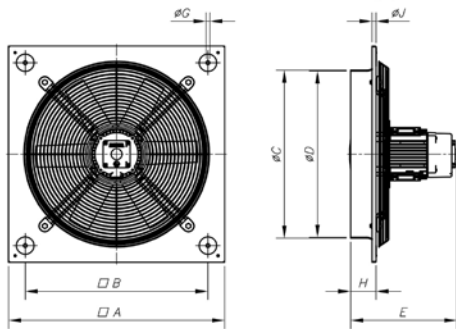

HCDF 56

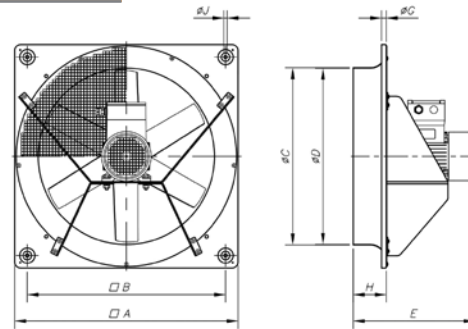

Model	A	B	ØC	ØD	E	G	H	ØI	ØJ
HCDF-25-4T	330	275	262	260	275	11	56	110	8.5
HCDF-25-4M	330	275	262	260	275	11	56	110	8.5
HCDF-31-4T	400	336	310.5	308	285	11	65	110	10.5
HCDF-31-4M	400	336	310.5	308	285	11	65	110	10.5
HCDF-35-4T	465	390	362.5	360	296	11	76	110	10.5
HCDF-35-4M	465	390	362.5	360	296	11	76	110	10.5
HCDF-40-4T	532	452	412.5	410	335	11	98	136	10.5
HCDF-40-4M	532	452	412.5	410	335	11	98	136	10.5
HCDF-45-4T	596	504	462.5	460	331	11	105	136	10.5
HCDF-45-4M	596	504	462.5	460	331	11	105	136	10.5
HCDF-45-6T	596	504	462.5	460	338	11	105	136	10.5
HCDF-50-4T	665	562	516.5	514	345	11	115	136	10.5
HCDF-56-4T	710	630	563	560	397	15	115	-	10.5
HCDF-56-6T	710	630	563	560	386	15	115	-	10.5

HDF

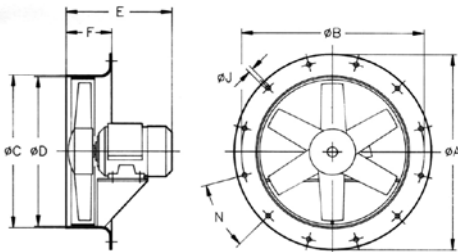

Model	ØA	ØB	ØC	D	E	F	ØJ	N
HDF-63-4T	730	690	645	640	370	150	12	12x30°
HDF-63-6T	730	690	645	640	330	150	12	12x30°
HDF-71-4T	810	770	715	710	349	150	12	16x22°30'
HDF-71-6T	810	770	715	710	323	150	12	16x22°30'
HDF-80-4T	900	860	805	800	421	180	12	16x22°30'
HDF-80-6T	900	860	805	800	371	180	12	16x22°30'
HDF-90-4T	1015	970	906	900	457	180	15	16x22°30'
HDF-90-6T	1015	970	906	900	415	180	15	16x22°30'

Characteristic curves

Q = Airflow in m³/h, m³/s and cfm.

Pe = Static pressure in mmH₂O, Pa and inwg.

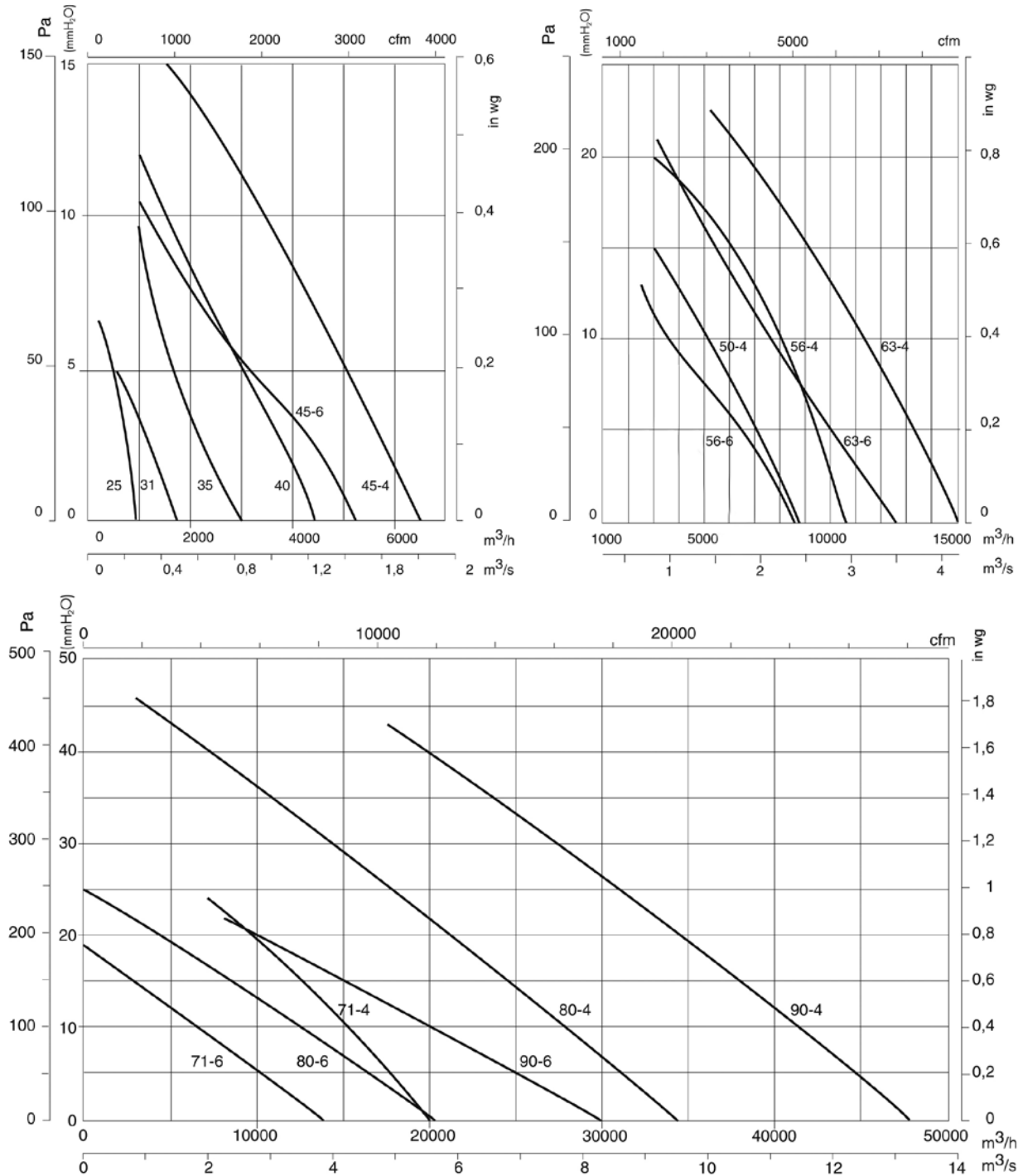

Accessories

See accessories section.

