

HPX/ATEX *Cased axial fans with external motor and ATEX certification*



Cased belt-driven axial fans with casing opening up to 180° to work in explosive atmospheres.

Fan:

- Sheet steel long casing with aluminium strip in the impeller area in accordance with Standard EN-14986:2007
- Impellers made from cast aluminium
- Pulley and belt protector with copper coating to prevent sparks
- Sealed transmission unit (IP66) with double retention system
- Airflow direction from motor to impeller
- Maximum temperature of air to be transported: -20°C +120°C

Motor:

- Class F insulation, IP55, with ATEX certification, Ex"e" explosion-proof and Ex"d", Ex tc, or Ex tb flame-resistant
- Three phase, 50Hz, 230/400V motors up to and including 4kW. 400/690V over 4kW

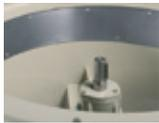

Aluminium strip to prevent sparks as per the EN-14986:2007 standard



Ex "e" marked: $\text{C} \llcorner \text{Ex} \text{ II 2G Ex e}$
 Ex "d" marked: $\text{C} \llcorner \text{Ex} \text{ II 2G Ex d}$
 Ex "n" marked: $\text{C} \llcorner \text{Ex} \text{ II 3G}$
 Ex tc marked: $\text{C} \llcorner \text{Ex} \text{ II 3D Ex tc}$
 Ex tb marked: $\text{C} \llcorner \text{Ex} \text{ II 2D Ex tb}$
 Notified authority: L.O.M
 Identification No: LOM3ATEX0132

Finish:

- Rust retardant finish with ATEX paint, containing no ferrous components, in polyester resin polymerised at 190°C, after phosphate free pre-treatment

On request:

- Built-in motors with PTC
- Special windings for different electrical supplies and frequencies
- ATEX construction for different categories
- Fans with two-speed motor.
- Ex "nA" version equipped with ATEX Ex nA motors

Order code

HPX/ATEX — 63 — 4T — 2 — Ex-e

Cased axial fans with external motor and ATEX certification

Marked:

- $\text{C} \llcorner \text{Ex} \text{ II 2G c}$
- $\text{C} \llcorner \text{Ex} \text{ II 3G c}$
- $\text{C} \llcorner \text{Ex} \text{ II 2D c}$
- $\text{C} \llcorner \text{Ex} \text{ II 3D c}$

Impeller diameter (cm)

Number of motor pole
 2=2900 r/min. 50 Hz
 4=1400 r/min. 50 Hz

T=Three-phase Motor
 M=Single-phase power (HP)

Ex-e marked: $\text{C} \llcorner \text{Ex} \text{ II 2G Ex e IIB T3}$
 Ex "d" marked: $\text{C} \llcorner \text{Ex} \text{ II 2G Ex d IIB T5}$
 Ex tc marked: $\text{C} \llcorner \text{Ex} \text{ II 3D Ex tc}$
 Ex tb marked: $\text{C} \llcorner \text{Ex} \text{ II 2D Ex tb}$

Technical characteristics

Model	Speed (r/min)	Maximum admissible current (A)			Installed power (kW)	Maximum airflow (m³/h)	Sound pressure level dB(A)	Approx. weight (Kg)
		230V	400V	690V				
HPX/ATEX-35-2T-0.75	2710	2.94	1.70		0.55	4750	77	22
HPX/ATEX-35-4T-0.33	1370	2.08	1.20		0.25	2500	60	20
HPX/ATEX-45-4T-0.33	1370	2.08	1.20		0.25	6300	69	32
HPX/ATEX-45-4T-0.50	1370	2.60	1.50		0.37	6600	70	36
HPX/ATEX-50-4T-0.75	1410	2.94	1.70		0.55	9000	70	33
HPX/ATEX-50-4T-1	1410	3.81	2.20		0.75	10800	71	34
HPX/ATEX-56-4T-0.75	1410	2.94	1.70		0.55	11300	72	36
HPX/ATEX-56-4T-1	1410	3.81	2.20		0.75	12200	73	36
HPX/ATEX-56-4T-1.5	1410	5.20	3.00		1.10	14500	75	39
HPX/ATEX-63-4T-1.5	1410	5.20	3.00		1.10	16000	74	59
HPX/ATEX-63-4T-2	1400	6.93	4.00		1.50	17500	78	63
HPX/ATEX-71-4T-1.5	1410	5.20	3.00		1.10	20300	78	74
HPX/ATEX-71-4T-2	1400	6.93	4.00		1.50	22500	79	77
HPX/ATEX-71-4T-3	1410	9.01	5.20		2.20	24000	81	85
HPX/ATEX-80-4T-3	1410	9.01	5.20		2.20	29000	83	95
HPX/ATEX-80-4T-4	1440	12.30	7.10		3.00	32000	84	100
HPX/ATEX-80-4T-5.5	1450	15.76	9.10		4.00	40500	84	106
HPX/ATEX-90-4T-5.5	1450	15.76	9.10		4.00	44000	89	118
HPX/ATEX-90-4T-7.5	1440		12.00	6.93	5.50	51000	91	132
HPX/ATEX-100-4T-10	1448		16.30	9.41	7.50	63000	93	159
HPX/ATEX-100-4T-15	1460		23.80	13.74	11.00	68000	94	181

Acoustic features

The specified values are determined according to free field measurements of pressure and sound levels in dB(A) at an equivalent distance of twice the fan's span plus the impeller's diameter, with a minimum of 1.5 m.

Sound power Lw(A) spectrum in dB(A) via frequency band in Hz.

Model	63	125	250	500	1000	2000	4000	8000	Model	63	125	250	500	1000	2000	4000	8000
35-2-0.75	48	63	82	81	82	81	76	67	71-4-1.5	55	75	83	88	90	87	80	69
35-4-0.33	31	46	65	64	65	64	59	50	71-4-2	56	76	84	89	91	88	81	70
45-4-0.33	40	55	74	73	74	73	68	59	71-4-3	65	76	86	92	93	88	77	73
45-4-0.50	41	56	75	74	75	74	69	60	80-4-3	60	80	88	93	95	92	85	74
50-4-0.75	44	58	77	77	78	76	72	63	80-4-4	61	81	89	94	96	93	86	75
50-4-1	45	59	78	78	79	77	73	64	80-4-5.5	68	79	89	95	96	91	80	76
56-4-0.75	47	67	75	80	82	79	72	61	90-4-5.5	67	88	95	100	103	99	92	81
56-4-1	48	68	76	81	83	80	73	62	90-4-7.5	69	90	97	102	105	101	94	83
56-4-1.5	57	68	78	84	85	80	69	65	100-4-10	73	93	100	106	108	105	98	87
63-4-1.5	51	71	79	84	86	83	76	65	100-4-15	74	94	101	107	109	106	99	88
63-4-2	62	73	83	89	90	85	74	70									

Dimensions in mm

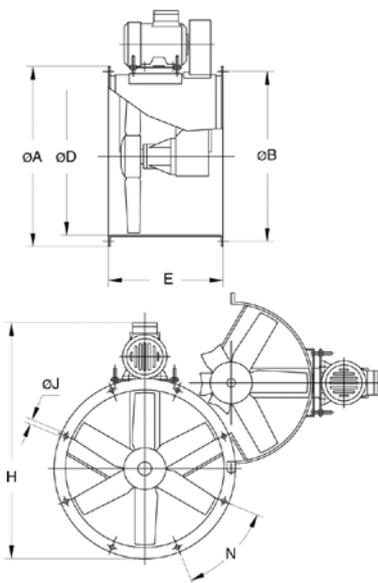

Model	ØA	ØB	ØD	E	H	ØJ	N
HPX-35-2T-0.75	425	395	355	380	606	10	8x45°
HPX-35-4T-0.16	425	395	355	380	609	10	8x45°
HPX-45-4T-0.33	540	500	460	420	740	12	8x45°
HPX-45-4T-0.50	540	500	460	420	728	12	8x45°
HPX-50-4T-0.75	600	560	512	420	803	12	12x30°
HPX-50-4T-1	600	560	512	420	803	12	12x30°
HPX-56-4T-0.75	660	620	560	450	848	12	12x30°
HPX-56-4T-1	660	620	560	450	848	12	12x30°
HPX-56-4T-1.5	600	620	560	450	870	12	12x30°
HPX-63-4T-1.5	730	690	640	500	950	12	12x30°
HPX-63-4T-2	730	690	640	500	950	12	12x30°
HPX-71-4T-1.5	810	770	710	550	1017	12	16x22°30'
HPX-71-4T-2	810	770	710	550	1017	12	16x22°30'
HPX-71-4T-3	810	770	710	550	1035	12	16x22°30'
HPX-80-4T-3	900	860	800	600	1173	12	16x22°30'
HPX-80-4T-4	900	860	800	600	1173	12	16x22°30'
HPX-80-4T-5.5	900	860	800	600	1200	12	16x22°30'
HPX-90-4T-5.5	1015	970	900	650	1320	15	16x22°30'
HPX-90-4T-7.5	1015	970	900	650	1320	15	16x22°30'
HPX-100-4T-10	1115	1070	1000	750	1483	15	16x22°30'
HPX-100-4T-15	1115	1070	1000	750	1513	15	16x22°30'

Characteristic curves

Q = Airflow in m³/h, m³/s and cfm.

Pe = Static pressure in mmH₂O, Pa and inwg.

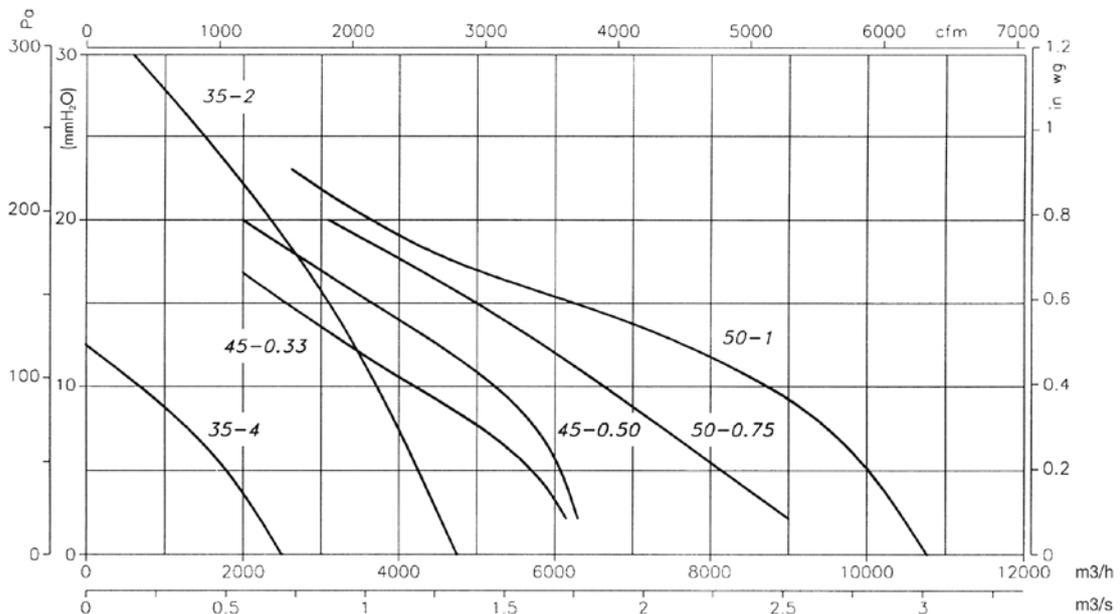

Characteristic curves

Q = Airflow in m³/h, m³/s and cfm.

Pe= Static pressure in mmH₂O, Pa and inwg.

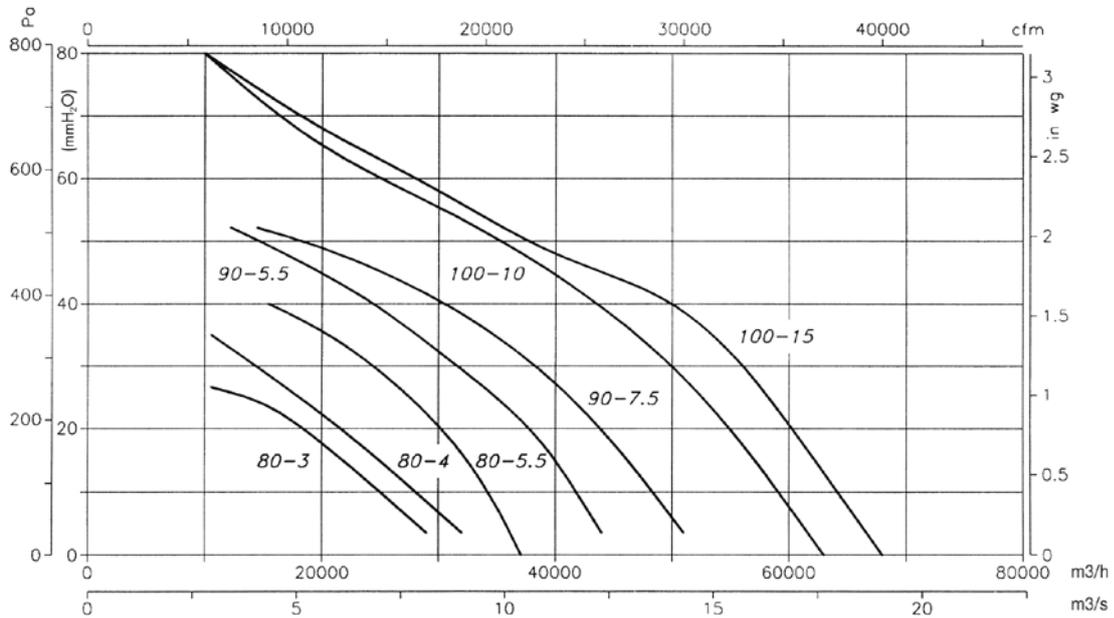
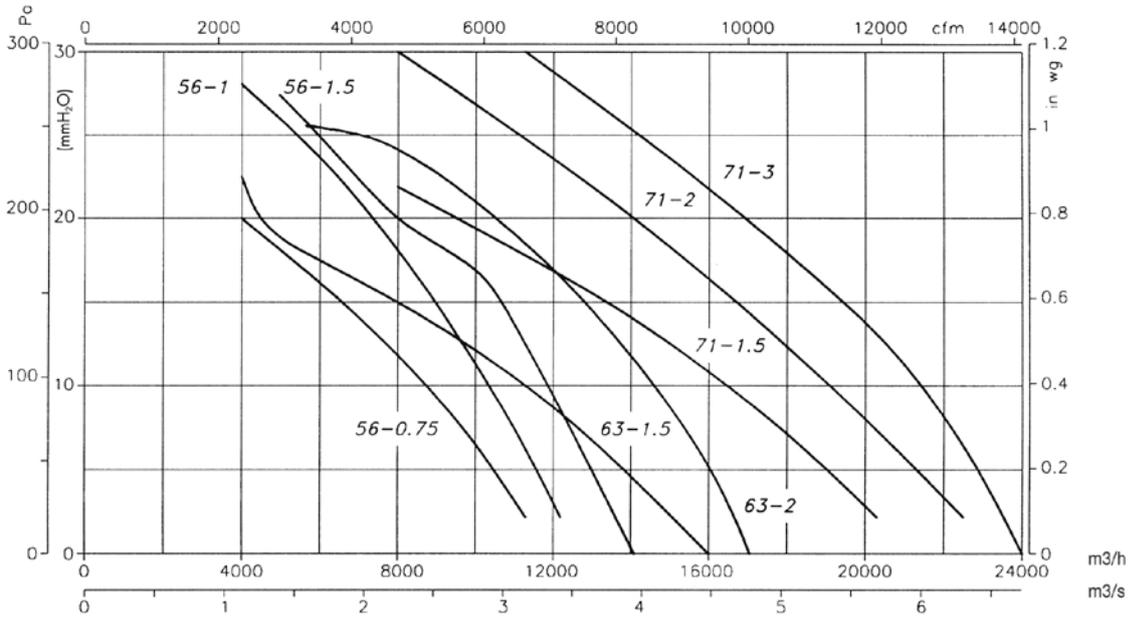

Accessories

See accessories section.

