

CBX CBXC CBXR CBXT



CBX: Belt-driven double-inlet centrifugal fans with shaft outlet on both sides and forward-curved impeller.

CBXC: Belt-driven double-inlet centrifugal fans with an extremely rigid cube-like structure to reinforce the casing.

CBXR: Belt-driven double-inlet centrifugal fans with a reinforced structure and rigid bridge bearings resting on the structure.

CBXT: Belt-driven double-inlet centrifugal fans fitted with electric motors, pulleys, belts, protectors and forward-curved impellers.



CBX



CBXC



CBXR

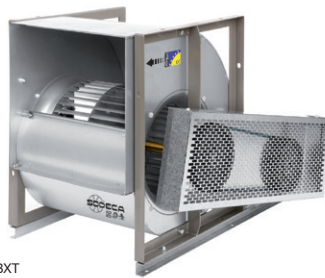

CBXT

Fan:

- Galvanised sheet steel casing.
- Forward-curved impeller made of galvanised sheet steel.
- CBX and CBXC: Bearings resting on rubber shock absorbers to prevent vibrations.
- CBX: Supplied with PSB support feet.

- Maximum temperature of air to be carried: CBX, CBXC and CBXT: -20 °C +80 °C CBXR: -20 °C +110 °C.

Finish:

- Anti-corrosive finish on galvanised sheet steel.

On request:

- CBX: The motor support and SM belt tensioner can be supplied.

Motor:

- IE3 efficiency motors for powers equal to or greater than 0.75 kW except single-phase, 2-speed and 8-pole.
- Free shaft with permanently-greased ball bearings on both sides.

Order code

CBXC — 12/12



CBX: Double-inlet centrifugal fans with free shaft outlets.



Impeller size in inches

CBXC: Double-inlet centrifugal fans with a cube-like structure.

CBXR: Double-inlet centrifugal fans with a reinforced structure.

CBXT — 12/12 — 1.5



CBXT: Double inlet, belt-driven centrifugal fans fitted with electric motors.



Impeller size in inches



Motor power (HP)

Technical characteristics

	Equivalence inches	Max. speed (r/min)	Max. installed power (kW)	Maximum flow rate (m ³ /h)	Air temperature (°C) min./max.		Approx. weight (kg)	According to ErP
CBX-1919	7/7	2500	1.10	3650	-20	+80	5.0	2015
CBX-2525	9/9	1800	1.50	5700	-20	+80	9.0	2015
CBX-2828	10/10	1700	1.50	6500	-20	+80	10.5	2015
CBX-3333	12/12	1400	1.50	8050	-20	+80	15.5	2015
CBX-3939	15/15	1000	1.50	11000	-20	+80	24.0	2015
CBX-4747	18/18	700	1.50	14500	-20	+80	33.5	2015

	Max. speed (r/min)	Max. installed power (kW)	Maximum flow rate (m ³ /h)	Air temperature (°C) min./max.		Approx. weight (kg)	According to ErP
CBXC-7/7	2500	1.10	3650	-20	+80	6.0	2015
CBXC-9/9	2100	1.50	5700	-20	+80	11.5	2015
CBXC-10/10	1700	1.50	6500	-20	+80	13.5	2015
CBXC-12/12	1400	2.20	9150	-20	+80	18.5	2015
CBXC-15/15	1100	3.00	13650	-20	+80	27.5	2015
CBXC-18/18	900	3.00	19050	-20	+80	38.5	2015

	Max. speed (r/min)	Max. installed power (kW)	Maximum flow rate (m ³ /h)	Air temperature (°C) min./max.		Approx. weight (kg)	According to ErP
CBXR-15/15	1200	5.50	16850	-20	+80	28.5	2015
CBXR-18/18	1000	7.50	26000	-20	+80	40.0	2015
CBXR-20/20	1000	9.00	29000	-20	+110	84.0	2015
CBXR-22/22	900	13.00	36000	-20	+110	94.0	2015
CBXR-25/25	700	13.00	48000	-20	+110	113.0	2015
CBXR-30/28	600	15.00	62000	-20	+110	145.0	2015

	Speed (r/min)	Maximum admissible current (A)			Installed power (kW)	Maximum flow rate (m ³ /h)	Air temperature (°C) min./max.		Approx. weight (kg)	Mounting version	According to ErP
		230 V	400 V	690 V							
CBXT-7/7-0.5	1420	2.02	1.17	0.37	1250	-20	+80	39.0	A	2015	
CBXT-7/7-0.75	1600	2.92	1.69	0.55	1450	-20	+80	41.0	A	2015	
CBXT-7/7-1 IE3	1790	3.10	1.79	0.75	1500	-20	+80	42.5	A	2015	
CBXT-9/9-0.25	825	1.23	0.71	0.18	1700	-20	+80	48.0	A	2015	
CBXT-9/9-0.33	920	1.66	0.96	0.25	1800	-20	+80	50.0	A	2015	
CBXT-9/9-0.5	1020	2.02	1.17	0.37	2200	-20	+80	51.5	A	2015	
CBXT-9/9-0.75	1050	2.92	1.69	0.55	2900	-20	+80	54.5	A	2015	
CBXT-9/9-1 IE3	1070	3.10	1.79	0.75	3200	-20	+80	56.0	A	2015	
CBXT-9/9-1.5 IE3	1260	4.03	2.32	1.10	3750	-20	+80	59.0	A	2015	
CBXT-10/10-0.75	845	2.92	1.69	0.55	3800	-20	+80	57.0	A	2015	
CBXT-10/10-1 IE3	960	3.10	1.79	0.75	4175	-20	+80	58.5	A	2015	
CBXT-10/10-1.5 IE3	1070	4.03	2.32	1.10	4800	-20	+80	61.3	A	2015	
CBXT-10/10-2 IE3	1140	5.96	3.44	1.50	5400	-20	+80	64.6	A	2015	
CBXT-12/12-0.5	595	2.02	1.17	0.37	4200	-20	+80	69.0	A	2015	
CBXT-12/12-0.75	675	2.92	1.69	0.55	4800	-20	+80	71.0	A	2015	
CBXT-12/12-1 IE3	765	3.10	1.79	0.75	5400	-20	+80	72.4	A	2015	
CBXT-12/12-1.5 IE3	855	4.03	2.32	1.10	5800	-20	+80	75.3	A	2015	
CBXT-12/12-2 IE3	965	5.96	3.44	1.50	6500	-20	+80	78.6	A	2015	
CBXT-12/12-3 IE3	1180	8.36	4.83	2.20	7400	-20	+80	87.0	B	2015	
CBXT-15/15-0.75	525	2.92	1.69	0.55	5900	-20	+80	85.0	B	2015	
CBXT-15/15-1 IE3	595	3.10	1.79	0.75	6500	-20	+80	86.4	B	2015	
CBXT-15/15-1.5 IE3	635	4.03	2.32	1.10	7500	-20	+80	89.3	B	2015	
CBXT-15/15-2 IE3	670	5.96	3.44	1.50	8200	-20	+80	92.6	B	2015	
CBXT-15/15-3 IE3	740	8.36	4.83	2.20	9500	-20	+80	101.0	B	2015	
CBXT-15/15-4 IE3	805	10.96	6.33	3.00	10600	-20	+80	103.0	B	2015	
CBXT-15/15-5.5 IE3	965	14.10	8.12	4.00	12000	-20	+80	108.0	B	2015	
CBXT-18/18-1.5 IE3	480	4.03	2.32	1.10	9000	-20	+80	122.0	B	2015	
CBXT-18/18-2 IE3	605	5.96	3.44	1.50	9250	-20	+80	125.3	B	2015	
CBXT-18/18-3 IE3	590	8.36	4.83	2.20	11500	-20	+80	133.7	B	2015	
CBXT-18/18-4 IE3	640	10.96	6.33	3.00	13200	-20	+80	135.7	B	2015	

CENTRIFUGAL FANS AND IN-LINE DUCT EXTRACTOR FANS

Technical characteristics

	Speed (r/min)	Maximum admissible current (A)			Installed power (kW)	Maximum flow rate (m³/h)	Air temperature (°C)		Approx. weight (kg)	Mounting version	According to ErP
		230 V	400 V	690 V			min./max.				
CBXT-18/18-5.5 IE3	675	14.10	8.12		4.00	15000	-20	+80	141.0	B	2015
CBXT-18/18-7.5 IE3	760		11.60	6.72	5.50	17000	-20	+80	154.5	B	2015
CBXT-20/20-2 IE3	430	5.96	3.44		1.50	11500	-20	+80	222.0	B	2015
CBXT-20/20-3 IE3	530	8.36	4.83		2.20	12800	-20	+80	230.5	B	2015
CBXT-20/20-4 IE3	575	10.96	6.33		3.00	14200	-20	+80	232.5	B	2015
CBXT-20/20-5.5 IE3	635	14.10	8.12		4.00	15500	-20	+80	237.5	B	2015
CBXT-20/20-7.5 IE3	675		11.60	6.72	5.50	17500	-20	+80	251.5	B	2015
CBXT-20/20-10 IE3	725		14.20	8.20	7.50	20000	-20	+80	266.5	B	2015
CBXT-22/22-2 IE3	385	5.96	3.44		1.50	14000	-20	+80	250.0	B	2015
CBXT-22/22-3 IE3	475	8.36	4.83		2.20	15000	-20	+80	257.0	B	2015
CBXT-22/22-4 IE3	515	10.96	6.33		3.00	17000	-20	+80	261.0	B	2015
CBXT-22/22-5.5 IE3	570	14.10	8.12		4.00	19000	-20	+80	265.0	B	2015
CBXT-22/22-7.5 IE3	605		11.60	6.72	5.50	21500	-20	+80	279.0	B	2015
CBXT-22/22-10 IE3	725		14.20	8.20	7.50	22000	-20	+80	290.0	B	2015
CBXT-22/22-15 IE3	765		20.20	11.60	11.00	27000	-20	+80	316.0	B	2015
CBXT-25/25-3 IE3	375	8.36	4.83		2.20	17000	-20	+80	297.0	B	2015
CBXT-25/25-4 IE3	405	10.96	6.33		3.00	20500	-20	+80	299.0	B	2015
CBXT-25/25-5.5 IE3	450	14.10	8.12		4.00	22000	-20	+80	304.0	B	2015
CBXT-25/25-7.5 IE3	485		11.60	6.72	5.50	24500	-20	+80	318.0	B	2015
CBXT-25/25-10 IE3	545		14.20	8.20	7.50	28000	-20	+80	329.0	B	2015
CBXT-25/25-15 IE3	610		20.20	11.60	11.00	32000	-20	+80	349.0	B	2015
CBXT-30/28-3 IE3	330	8.36	4.83		2.20	20000	-20	+80	380.0	B	2015
CBXT-30/28-4 IE3	360	10.96	6.33		3.00	22000	-20	+80	382.0	B	2015
CBXT-30/28-5.5 IE3	380	14.10	8.12		4.00	25000	-20	+80	387.0	B	2015
CBXT-30/28-7.5 IE3	380		11.60	6.72	5.50	31500	-20	+80	402.0	B	2015
CBXT-30/28-10 IE3	410		14.20	8.20	7.50	36000	-20	+80	415.0	B	2015
CBXT-30/28-15 IE3	430		20.20	11.60	11.00	42000	-20	+80	426.0	B	2015
CBXT-30/28-20 IE3	480		27.50	15.90	15.00	48000	-20	+80	449.0	B	2015



Erp. (Energy Related Products)

Information on Directive 2009/125/EC can be downloaded from the SODECA website or the QuickFan selector programme.

Dimensions mm

CBX
Standard
supply RD 90

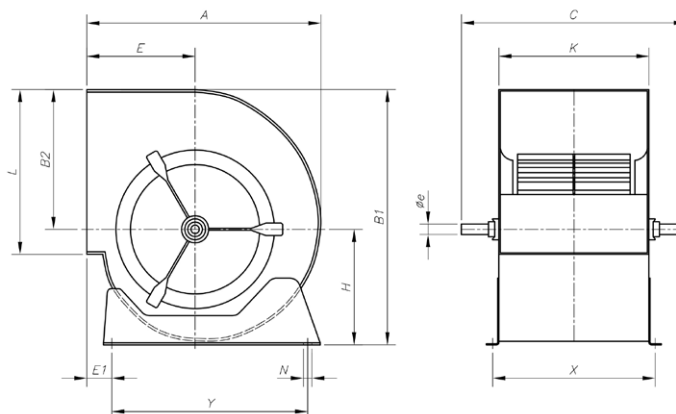

	Equiv. inch.	A	B1	B2	C	E	E1	H	K	L	N	øe	X	Y
CBX-1919	7/7	316	333	189	360	152	64	144	230	208	9x13	20	258	225
CBX-2525	9/9	380	400	218	430	183	78	182	300	263	9x13	20	328	275
CBX-2828	10/10	422	450	246	470	202	73	204	326	292	9x17	20	355	315
CBX-3333	12/12	493	526	290	560	230	82	236	387	345	9x17	25	415	390
CBX-3939	15/15	579	621	348	650	265	92	273	473	404	9x17	25	500	455
CBX-4747	18/18	686	746	415	750	323	82	331	540	482	9x17	25	568	575

Dimensions mm

CBXC Standard supply RD 90

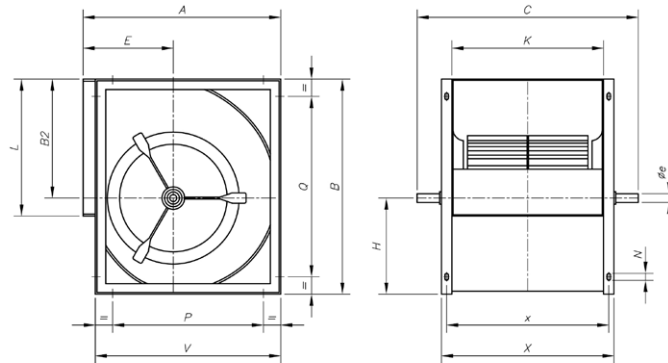

	A	B	B2	C	E	øe	H	K	L	N	P	Q	V	X	x
CBXC-7/7	322	342	189	360	152	20	153	230	208	9x17	148	175	292	290	262
CBXC-9/9	388	402	218	430	183	20	184	300	263	9x17	214	214	358	360	332
CBXC-10/10	428	450	246	470	202	20	204	326	292	9x17	254	254	398	386	358
CBXC-12/12	498	532	290	560	230	25	242	387	345	9x17	324	324	468	447	419
CBXC-15/15	583	632	348	650	265	25	284	473	404	9x17	406	406	553	533	505
CBXC-18/18	694	756	415	750	323	25	341	540	482	9x17	520	608	664	600	572

CBXR Standard supply RD 90

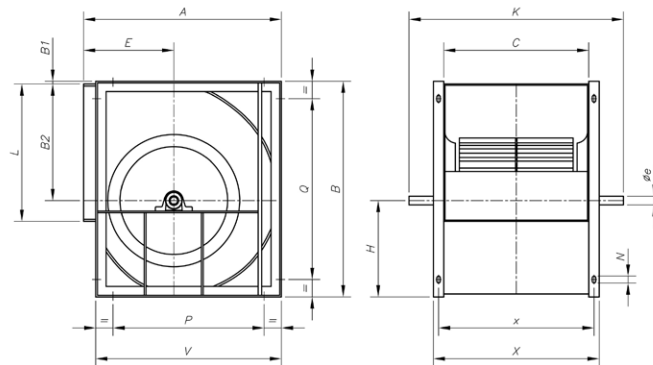

	A	B	B1	B2	C	E	øe	H	K	L	N	P	Q	V	X	x
CBXR-15/15	583	632	-	348	473	265	25	284	730	404	9x17	406	406	553	533	505
CBXR-18/18	694	756	-	415	540	323	25	341	800	482	9x17	520	608	664	600	572
CBXR-20/20	843	963	35	523	603	375	35	405	923	603	13x25	646	811	798	683	643
CBXR-22/22	913	1046	35	569	656	400	35	442	976	693	13x25	716	894	868	736	696
CBXR-25/25	998	1161	35	642	765	423	35	484	1085	793	13x25	801	1009	953	845	805
CBXR-30/28	1206	1400	35	776	888	515	40	589	1208	933	13x25	1009	1248	1161	968	928

CENTRIFUGAL FANS AND IN-LINE DUCT EXTRACTOR FANS

Dimensions mm

**CBXT
Assembly A
Standard
supply RD 90**

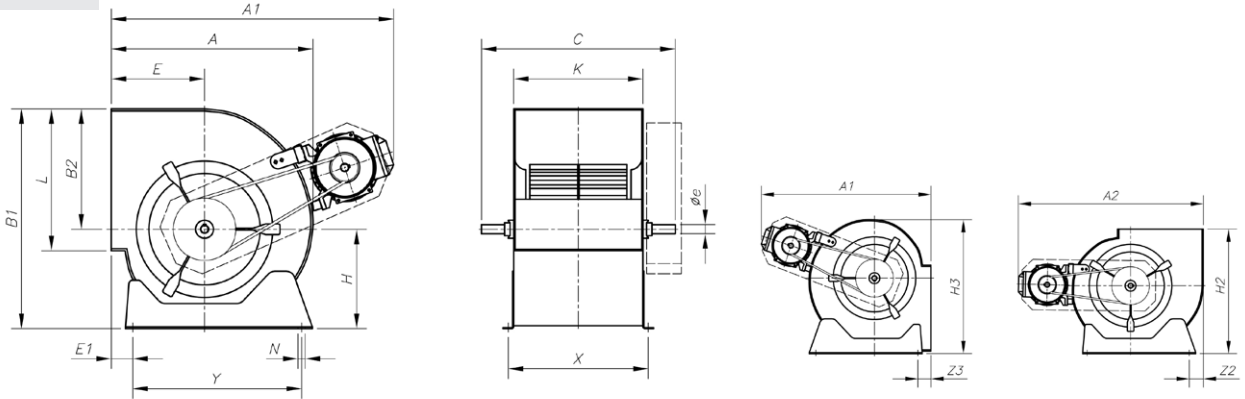

	A	A1	A2	B1	B2	C	E	E1	øe	H	H2	H3	K	L	N	X	Y	Z2	Z3
CBXT-7/7-0.5	316	450	495	333	189	360	152	64	20	144	320	341	230	208	9x13	258	225	44	36
CBXT-7/7-0.75	316	470	515	333	189	360	152	64	20	144	320	341	230	208	9x13	258	225	44	36
CBXT-7/7-1	316	470	515	333	189	360	152	64	20	144	320	341	230	208	9x13	258	225	44	36
CBXT-9/9-0.25	380	490	535	400	218	430	183	78	20	182	385	395	300	263	9x13	328	275	50	57
CBXT-9/9-0.33	380	520	565	400	218	430	183	78	20	182	385	395	300	263	9x13	328	275	50	57
CBXT-9/9-0.5	380	520	565	400	218	430	183	78	20	182	385	395	300	263	9x13	328	275	50	57
CBXT-9/9-0.75	380	540	585	400	218	430	183	78	20	182	385	395	300	263	9x13	328	275	50	57
CBXT-9/9-1	380	540	585	400	218	430	183	78	20	182	385	395	300	263	9x13	328	275	50	57
CBXT-9/9-1.5	380	590	605	400	218	430	183	78	20	182	385	395	300	263	9x13	328	275	50	57
CBXT-10/10-0.75	422	590	635	450	246	470	202	73	20	204	443	470	326	292	9x17	355	315	50	50
CBXT-10/10-1	422	590	635	450	246	470	202	73	20	204	443	470	326	292	9x17	355	315	50	50
CBXT-10/10-1.5	422	610	655	450	246	470	202	73	20	204	443	470	326	292	9x17	355	315	50	50
CBXT-10/10-2	422	610	655	450	246	470	202	73	20	204	443	470	326	292	9x17	355	315	50	50
CBXT-12/12-0.5	493	645	690	526	290	560	230	82	25	236	498	555	387	345	9x17	415	390	35	70
CBXT-12/12-0.75	493	665	710	526	290	560	230	82	25	236	498	555	387	345	9x17	415	390	35	70
CBXT-12/12-1	493	665	710	526	290	560	230	82	25	236	498	555	387	345	9x17	415	390	35	70
CBXT-12/12-1.5	493	680	725	526	290	560	230	82	25	236	498	555	387	345	9x17	415	390	35	70
CBXT-12/12-2	493	680	725	526	290	560	230	82	25	236	498	555	387	345	9x17	415	390	35	70

**CBXT
Assembly B
Standard
supply RD 90**

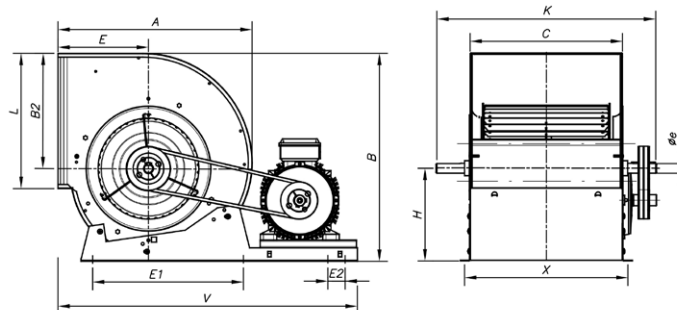

	A	B	B2	C	E	E1	E2	øe	H	K	L	V	X
CBXT 12/12-3	493.5	527.4	292.9	387	230	390	63	21	234.9	560	343	761	416

Dimensions mm

**CBXT
Assembly B
Standard
supply RD 90**

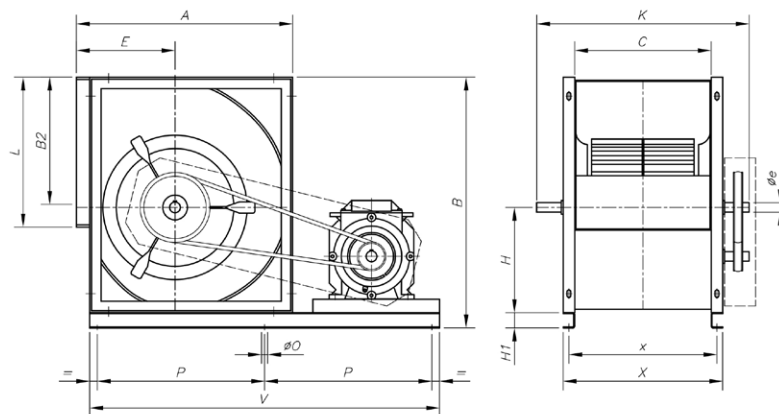

	A	B	B2	C	E	øe	H	H1	K	L	øO	P	V	x	X
CBXT-15/15 (0.75CV...4CV)	583	672	348	473	265	25	284	40	650	404	12	415.5	895	505	533
CBXT-18/18 (1.5CV...4CV)	694	796	415	540	323	25	341	40	750	482	12	515.5	1115	572	600

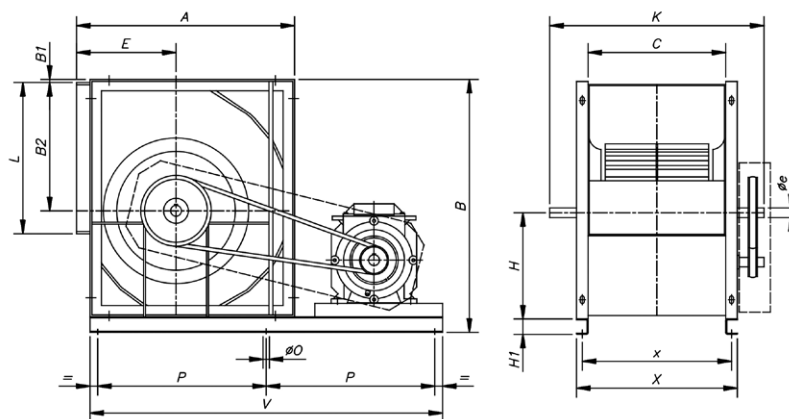

	A	B	B1	B2	C	E	øe	H	H1	K	L	øO	P	V	x	X
CBXT-15/15 (≥ 5.5 CV)	583	672	-	348	473	265	25	284	40	730	404	12	415.5	895	505	533
CBXT-18/18 (≥ 5.5 CV)	694	796	-	415	540	323	25	341	40	800	482	12	515.5	1115	572	600
CBXT-20/20	843	1023	35	523	603	375	35	405	60	923	603	12	617.5	1315	643	683
CBXT-22/22	913	1106	35	569	656	400	35	442	60	976	693	12	657.5	1395	696	736
CBXT-25/25	998	1221	35	642	765	423	35	484	60	1085	793	12	474.5	1575	805	845
CBXT-30/28	1206	1460	35	776	888	515	40	589	60	1208	933	12	817.5	1715	928	968