

# CPV



**Anti-corrosive finished, single inlet centrifugal fans made of polypropylene.**



#### Fan:

- Polypropylene casing.
- Forward-curved impeller made of polypropylene.

#### Motor:

- IE3 efficiency motors for powers equal to or greater than 0.75 kW except single-phase, 2-speed and 8-pole.
- Class F motors with ball bearings and IP55 protection.
- Three-phase 230/400 V - 50 Hz (up to 4 kW) and 400/690 V - 50 Hz (powers higher than 4 kW).
- Maximum temperature of air to be carried: -20 °C +70 °C.

#### Finish:

- Corrosive-proof in plastic material.

#### On request:

- Special windings for different voltages.
- ATEX-certified Category 2.



Modern appearance and design

## Order code

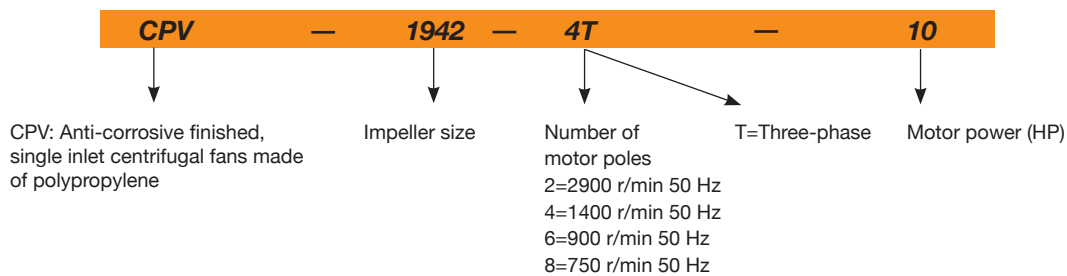

## Technical characteristics

Model	Speed (r/min)	Maximum admissible current (A)			Installed power (kW)	Maximum flow rate (m <sup>3</sup> /h)	Sound pressure level (dB(A))	Approx. weight (kg)
		230 V	400 V	690 V				
*CPV-720-2T	2710	1.92	1.11		0.37	525	75	10
*CPV-815-2T	2710	1.92	1.11		0.37	950	75	14
*CPV-815-4T	1350	1.52	0.88		0.25	450	58	14
CPV-825-2T IE3	2830	4.03	2.34		1.10	1140	79	18
CPV-930-2T IE3	2910	7.32	4.21		2.20	1750	84	29
CPV-1020-2T IE3	2825	2.80	1.62		0.75	2000	81	25
CPV-1020-4T	1350	1.52	0.88		0.25	1250	65	20
CPV-1020-6T	900	1.51	0.87		0.25	750	53	20
CPV-1160-4T IE3	1470		20.90	12.10	11.00	8000	83	268
CPV-1325-2T IE3	2910	7.32	4.21		2.20	3250	87	32
CPV-1325-4T	1370	2.02	1.17		0.37	2300	69	27
CPV-1325-6T	900	1.51	0.87		0.25	1400	59	27
CPV-1335-2T IE3	2930		10.10	5.86	5.50	4700	84	114
CPV-1630-4T IE3	1440	5.41	3.11		1.50	4500	75	43
CPV-1630-6T	900	2.99	1.73		0.55	2700	63	35
CPV-1840-4T IE3	1440	10.70	6.15		3.00	6000	70	53
CPV-1840-6T IE3	945	4.68	2.69		1.10	4200	65	48
*CPV-1942-4T-7.5 IE3	1465		10.30	5.97	5.50	8500	79	89
*CPV-1942-4T-10 IE3	1465		13.90	8.06	7.50	10500	84	93
*CPV-1942-6T IE3	950	9.08	5.22		2.20	7000	75	53
*CPV-1942-8T	705	7.10	4.10		1.50	5500	70	56
CPV-2045-4T IE3	1465		13.90	8.06	7.50	10400	78	118
CPV-2045-6T IE3	970	12.00	6.91		3.00	7000	72	88
CPV-2060-4T IE3	1470		20.90	12.10	11.00	12000	81	270
CPV-2160-4T IE3	1465		27.90	16.20	15.00	15500	77	299

\*Only LG admit position

**Acoustic characteristics**

The indicated values are determined by measuring the sound pressure level and sound power in dB(A) obtained in a free field at a distance equivalent to twice the size of the fan plus the impeller diameter, with a minimum of 1.5 m.

Sound power spectrum Lw(A) in dB(A) per Hz frequency band

Model	63	125	250	500	1000	2000	4000	8000	Model	63	125	250	500	1000	2000	4000	8000
720-2T	56	69	77	81	81	77	73	65	1630-4T	60	73	81	85	86	82	78	69
815-2T	56	69	77	81	81	77	73	65	1630-6T	48	61	69	73	74	70	66	57
815-4T	39	52	60	64	64	60	56	48	1840-4T	55	68	76	80	81	77	73	64
825-2T	60	73	81	85	85	81	77	69	1840-6T	50	63	71	75	76	72	68	59
930-2T	65	78	86	90	90	86	82	74	1942-4T-7,5	75	85	87	90	89	89	87	78
1020-2T	62	75	83	87	87	83	79	71	1942-4T-10	80	90	92	95	94	94	92	83
1020-4T	46	59	67	71	71	67	63	55	1942-6T	71	81	83	86	85	85	83	74
1020-6T	34	47	55	59	59	55	51	43	1942-8T	66	76	78	81	80	80	78	69
1160-4T	68	81	89	93	94	90	86	77	2045-4T	63	76	84	88	89	85	81	72
1325-2T	70	83	91	95	96	92	88	79	2045-6T	57	70	78	82	83	79	75	66
1325-4T	52	65	73	77	78	74	70	61	2060-4T	66	79	87	91	92	88	84	75
1325-6T	42	55	63	67	68	64	60	51	2160-4T	64	77	85	89	89	85	81	73
1335-2T	67	80	88	92	93	89	85	76									

**Dimensions mm**

CPV-720...1942

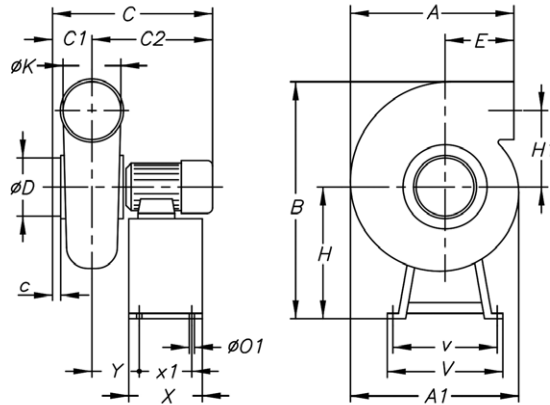

Fig.	A	A1	B	C	C1	C2	c	øD	E	H	H1	øK	øO1	V	v	X	x1	Y	
CPV-720	1	375	-	486	350	80	270	45	90	212	311	130	90	6	340	320	180	160	92
CPV-815	1	307	335	521	360	100	260	30	125	100	281	177.5	125	8	355	335	180	160	90
CPV-825	1	445	-	552	433	110	323	55	125	218	320	170	125	6	340	320	180	160	103
CPV-930	1	540	-	678	477	100	377	40	160	262	390	205	160	6	420	400	240	160	137
CPV-1020-2T	1	340	397	593	445.5	116	329.5	32	160	100	290	223	160	8	355	335	180	160	127.5
CPV-1020-4/6T	1	340	397	584	422.5	116	306.5	32	160	100	281	223	160	8	355	335	180	160	122.5
CPV-1325-2T	1	413	505	735	494	130	364	35	200	103	370	265	200	8	400	380	180	160	125
CPV-1325-4/6T	1	413	505	716	432.5	130	302.5	35	200	103	351	265	200	8	400	380	180	160	113.5
CPV-1630-4T	1	480	602	890	536.5	145	391.5	35	250	117	440	323	250	8	450	430	240	220	142.5
CPV-1630-6T	1	480	602	880	503	145	358	35	250	117	430	323	250	8	450	430	240	220	138
CPV-1942-4T	1	580	750	1170	730.5	210	520.5	60	315	130	600	412.5	315	8	600	564	350	314	181.5
CPV-1942-6/8T	1	580	750	1150	679.5	210	469.5	60	315	130	580	412.5	315	8	600	564	350	314	204

### Dimensions mm

#### CPV-1335...2045

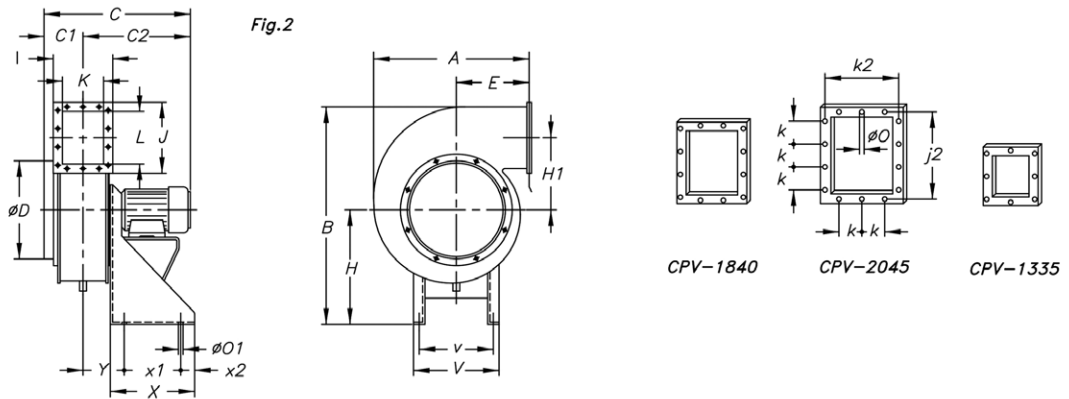

Fig.	A	B	C	C1	C2	øD	E	H	H1	I	J	j2	K	k	k2	L	
CPV-1335	2	566	788	675	175	500	225	255	452	246	240	256	226	160	100	210	180
CPV-1840-4T	2	628	819	660	210	450	355	275	420	259	305	356	326	225	100	275	280
CPV-1840-6T	2	628	809	630	210	420	355	275	410	259	305	356	326	225	100	275	280
CPV-2045	2	724	1020	810	245	565	400	300	542	310	362	421	381	270	100	322	335

	øO	øO1	V	v	X	x1	x2	Y
CPV-1335	9	12	320	285	-	200	50	140
CPV-1840-4T	9	12	320	285	300	200	50	170
CPV-1840-6T	9	12	320	285	300	200	50	170
CPV-2045	9	12	350	315	350	250	50	197

#### CPV-1160...2160

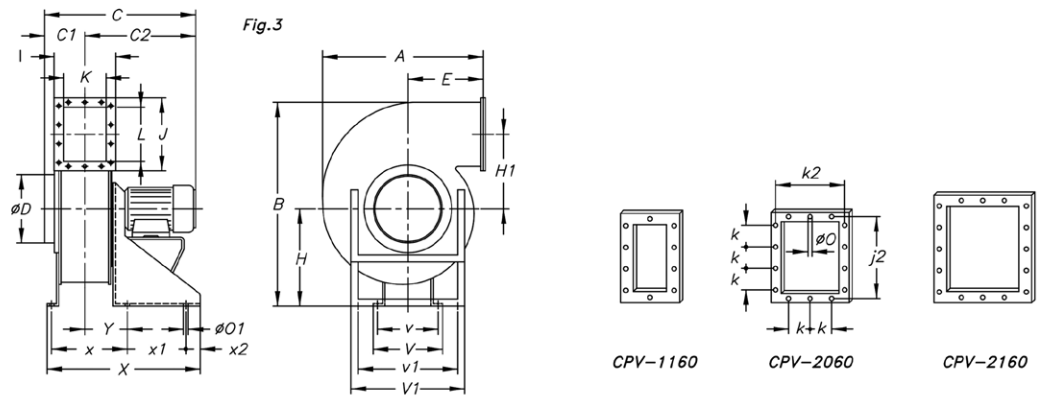

Fig.	A	B	C	C1	C2	øD	E	H	H1	I	J	j2	K	k	k2	L	
CPV-1160	3	937	1296	818	210	608	355	410	720	421	275	416	366	155	100	225	310
CPV-2060	3	937	1296	938	270	668	400	410	720	421	395	416	366	275	100	345	310
CPV-2160	3	981	1356	983	285	698	600	414	720	438.5	455	501	451	335	100	405	395

	øO	øO1	V	V1	v	v1	X	x	x1	x2	Y
CPV-1160	9	14	500	790	450	670	710	265	360	60	155
CPV-2060	9	14	500	790	450	670	855	410	360	60	215
CPV-2160	9	14	500	790	450	670	915	470	360	60	240

**Characteristic curves**

Q= Flow rate in m<sup>3</sup>/h, m<sup>3</sup>/s and cfm

Pe= Static pressure in mm H<sub>2</sub>O, Pa and inwg

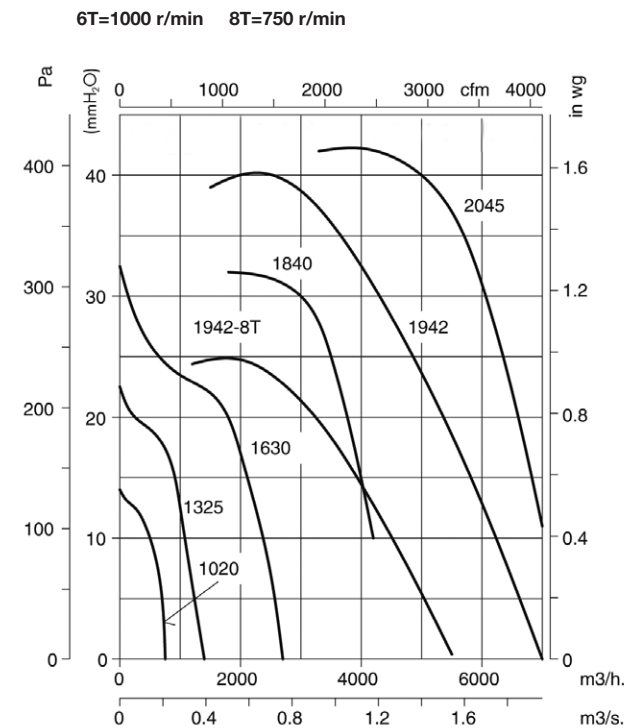
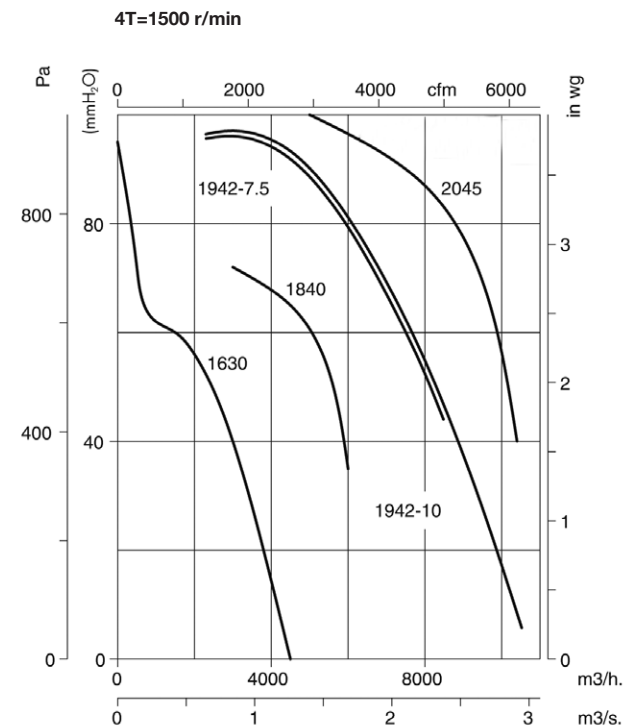
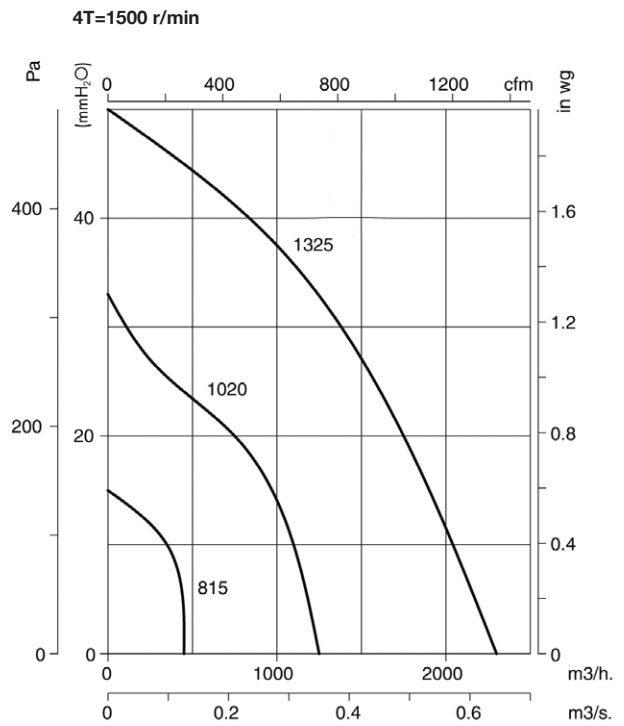
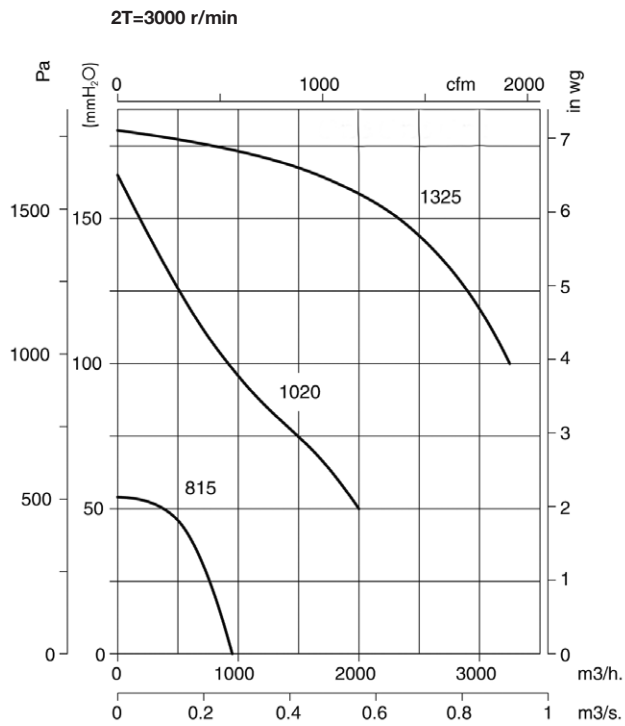

## Characteristic curves

Q= Flow rate in m<sup>3</sup>/h, m<sup>3</sup>/s and cfm

Pe= Static pressure in mm H<sub>2</sub>O, Pa and inwg

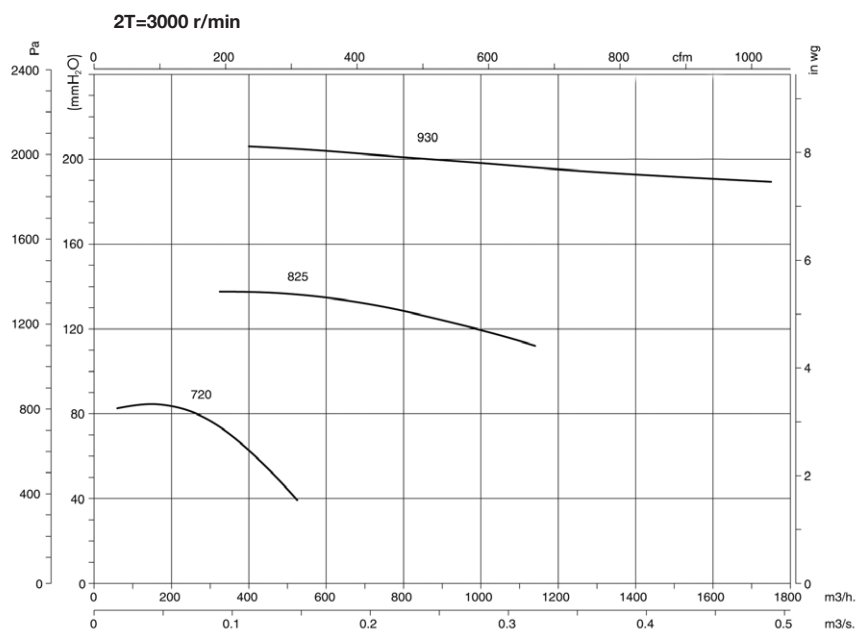
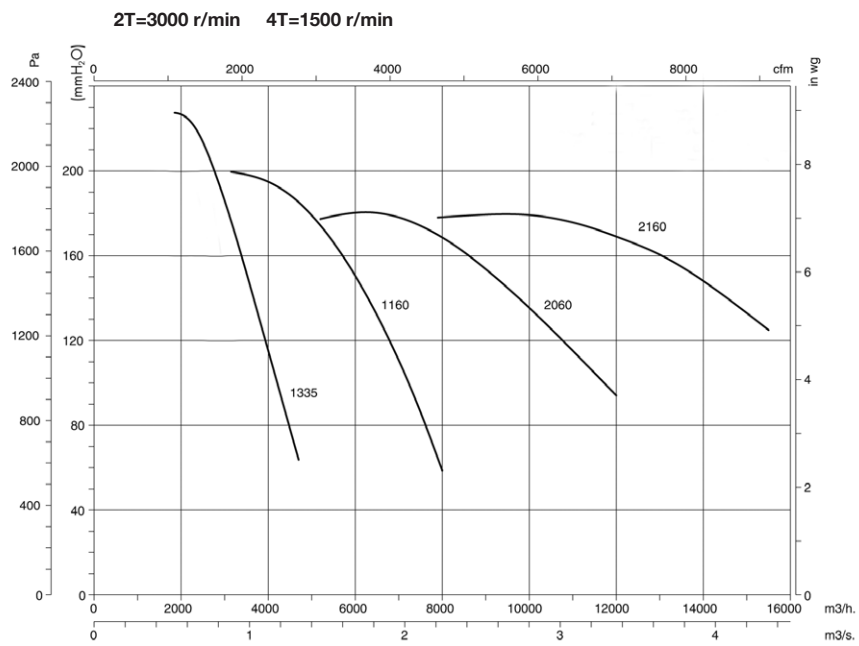

## Orientation

Standard supply LG 90



## Accessories

See accessories section.

