



CARATTERISTICHE:

Bocchette per canali circolari passo 20 mm.

COSTRUZIONE:

Acciaio zincato, o verniciato RAL 9010, RAL 9016, RAL 7035.

Su richiesta sono disponibili costruzioni in acciaio inox AISI 304 nelle finiture 2B o BA.

IMPIEGO:

A canale circolare, in mandata e ripresa.

Altezza di installazione: 2,5-3,5 m.

FISSAGGIO:

Fissaggio con viti frontali.

ACCESSORI:

- Serranda di taratura in acciaio zincato con alette a movimento contrapposto.
- Serranda captatrice.
- Serranda captatrice a deflettore unico.

CHARACTERISTICS:

Grilles for circular ducts 20 mm pitch.

CONSTRUCTION:

Galvanized steel, or painted in RAL 9010, RAL 9016, RAL 7035.

Models made of stainless steel AISI 304, 2B or BA finish, are available on demand.

UTILIZATION:

For circular duct installation, and for air intake and delivery. Installation height: 2,5-3,5 m.

FIXING:

Fixing by frontal screws.

Accessories:

- Calibration damper made of galvanized steel and fins with opposite movement.
- Getting damper.
- Single blade deflecting damper.

PREZZI - PRICES

BxH mm	Diametro condotto di installazione Diameter of duct mm	BMC1V0 BMC10V	BMC1V BMC10	BMC2V0 BMC20V	BMC2V BMC20	SC	SK	SB
		€	€	€	€	€	€	€
200x75	150 200 250							
300x75								
400x75								
500x75								
600x75								
800x75								
200x100	300 350 400 450							
300x100								
400x100								
500x100								
600x100								
• 800x100								
• 1000x100								
300x150	500 600 700 800							
400x150								
500x150								
600x150								
• 800x150								
• 1000x150								
400x200	900 1000 1100 1200							
500x200								
600x200								
• 800x200								
• 1000x200								

• Rinforzo intermedio - Intermediate reinforcing

DESCRIZIONI - DESCRIPTIONS:

BMC1: Bocchetta circolare adattabile tutti i diametri del condotto - Circular grille adaptable to all diameters of duct

BMC2: Bocchetta circolare con esatto diametro del condotto - Circular grille with the exact diameter of duct

BMCV: Bocchetta circolare a singolo filare di alette parallele al lato corto - Grille with single row of vertical bars

BMC0: Bocchetta a singolo filare di alette parallele al lato lungo - Grille with single row of horizontal bars

BMCV0: Bocchetta a doppio filare di alette (alette frontali parallele al lato corto, posteriori parallele al lato lungo) - Grille with double row of bars (frontal vertical, back horizontal)

BMC0V: Bocchetta a doppio filare di alette (alette frontali parallele al lato lungo, posteriori parallele al lato corto) - Grille with double row of bars (frontal horizontal, back vertical)

ACCESSORI - ACCESSORIES:

SC: Serranda di taratura ad alette con movimento contrapposto - Opposed blade damper

SK: Serranda captatrice - Getting damper

SB: Serranda a bandiera - Single blade deflecting damper

DISEGNI - DRAWINGS

BMC1

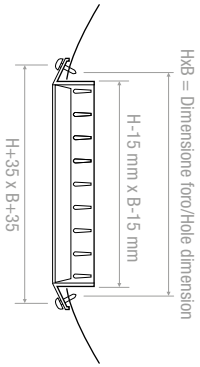

BMC2

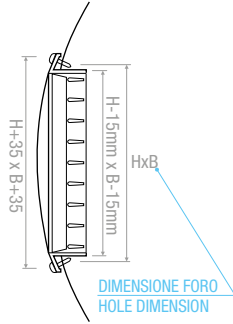

SK

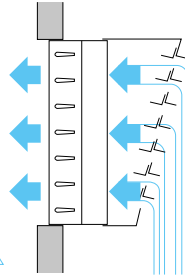

SB

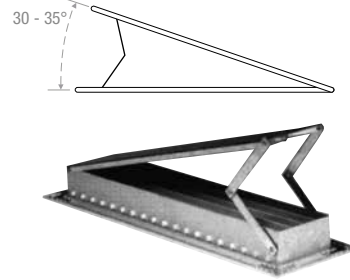

TIPO DI FISSAGGIO - TYPE OF FIXING

Fissaggio con viti
Fixing with screws

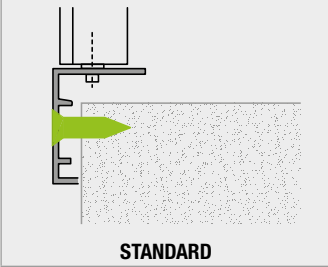

FORI - HOLE

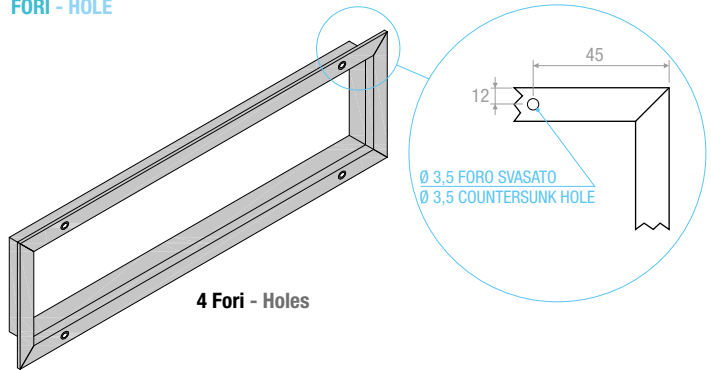

MOVIMENTAZIONE SERRANDA CAPTATRICE SK - HANDLING GETTING DAMPER SK

APERTURA ALETTE - OPEN BLADES

- 1) Far passare il gancio attraverso le alette della bocchetta e fermarlo sul foro posto sulla serranda captatrice (vedi Particolare Aggancio Aletta) - Pass the hook through the fins of the grille and secure it on the hole on getting damper (see Detail Hook Blade).
- 2) Spingere con il gancio le alette della serranda captatrice nella direzione indicata dalla freccia - Push the hook with the blades of the getting damper in the direction indicated by the arrow.
- 3) Togliere il gancio dalla aletta della serranda captatrice - Remove the hook from the blade of the getting damper.

CHIUSURA ALETTE - CLOSING BLADES

- 1) Far passare il gancio attraverso le alette della bocchetta e fermarlo sul foro posto sulla serranda captatrice (vedi Particolare Aggancio Aletta) - Pass the hook through the fins of the grille and secure it on the hole on getting damper (see Detail Hook Blade).
- 2) Tirare con il gancio le alette della serranda captatrice nella direzione indicata dalla freccia - Pull the hook with the blades of the getting damper in the direction indicated by the arrow.
- 3) Togliere il gancio dalla aletta della serranda captatrice - Remove the hook from the blade of the getting damper.



TABELLA DI SELEZIONE - SELECTION TABLE

Modello - Model	A _s [m ²]	Q [m ³ /h]		L _{wa} [dB(A)]		X _(0,25) [m]		Dp _t [Pa]	
		min	max	min	max	min	max	min	max
BMC 200x75	0,007275	70	135		37	2	2,8	5	20
BMC 300x75	0,011775	100	220		38	2,3	3,3	5	20
BMC 400x75	0,016575	150	300		40	2,5	3,7	5	20
BMC 500x75	0,21675	200	400		40	2,7	4,2	5	20
BMC 600x75	0,026925	250	500	20	41	3	4,6	5	20
BMC 800x75	0,038025	370	730	22	42	3,4	5,4	5	20
BMC 200x100	0,0097	90	180		38	2,6	3,5	5	20
BMC 300x100	0,0157	140	290		40	2,8	4	5	20
BMC 400x100	0,0221	200	400		40	3,1	4,4	5	20
BMC 500x100	0,0289	270	530		41	3,3	4,9	5	20
BMC 600x100	0,0359	330	660	20	42	3,5	5,3	5	20
BMC 800x100	0,0507	470	930	22	43	3,9	6,1	5	20
BMC 1000x100	0,0662	610	1210	22	44	4,2	6,7	5	20
BMC 300x150	0,0255	230	470		41	3,2	4,7	5	20
BMC 400x150	0,0359	330	660	20	42	3,5	5,3	5	20
BMC 500x150	0,0469	430	860	21	43	3,8	5,9	5	20
BMC 600x150	0,0584	540	1070	22	44	4,1	6,4	5	20
BMC 800x150	0,0823	760	1500	23	45	4,6	7,3	5	20
BMC 1000x150	0,1074	990	1960	24	45	5	8,2	5	20
BMC 400x200	0,0507	470	930	22	43	3,9	6,1	5	20
BMC 500x200	0,0662	610	1210	22	44	4,2	6,7	5	20
BMC 600x200	0,0823	760	1500	23	45	4,6	7,3	5	20
BMC 800x200	0,1161	1060	2120	24	46	5,1	8,5	5	20
BMC 1000x200	0,1515	1390	2770	25	47	5,7	9,6	5	20

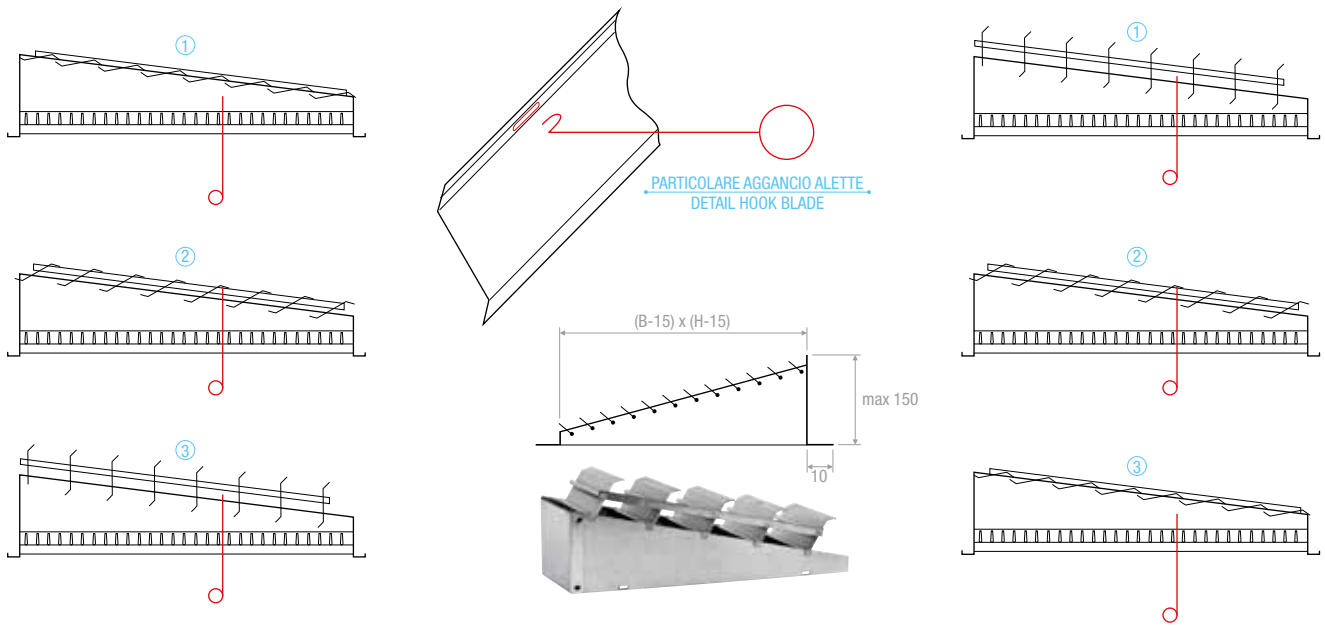